

FREEZE DRYER

HRC100



OVERVIEW

Patented technology preserves the taste, nutrition, and texture of nearly any food for up to 25 years. Perfect for freeze drying fruits, vegetables, meats, dairy products, meals, desserts, and more.

FEATURES

The HRC100 accommodates standard baking sheet trays and is able to handle 65-90 lbs of product per batch (depending on your product). Just press start and the freeze dryer will beep when finished. Though it is easy to use, expanded service level agreements are available for commercial clients.

DIMENSIONS

Overall Dimension Actual: 33.5" W x 37.25" D x 70" H
Tray Dimensions: 18" W x 26" D x 0.9" H
Tray Space: 29.25 sq. feet

WARRANTY

Expanded service level agreement available.

POWER

220 volt single phase outlet. A dedicated 30 amp circuit is required.

SHIPPING INFO

The HRC100 freeze dryer ships in one package with a total weight of 985 lbs.

MAINTENANCE

Service level agreement includes training on simple maintenance.



Power Receptacle
10-30r rated at 30A
125/250V.



10-30P NEMA Plug
rated at 30A 125/250V
(common dryer plug)

801.683.2755

HarvestRightCommercial.com

HRC PREMIER VACUUM PUMP

The freeze dryer itself requires little to no maintenance. However, all freeze dryers come with a high quality industrial vacuum pump, which requires some maintenance, mainly adding and draining oil. There are approximately 74 oz of oil in a vacuum pump. To keep the freeze dryer and pump running efficiently, the oil should be changed as often as needed. This is a simple process and requires little effort.

Each freeze dryer also includes a stand-alone oil filter. The filter cleans the oil and allows you to keep reusing your oil as if it were new. Using filtered oil in each batch is a great way to save money and be more eco-friendly, while also helping your vacuum pump perform as efficiently as possible.

SPECS

- Oil: Harvest Right Oil, Robinair Premium High Vacuum Pump Oil or JB Industries Black Gold Vacuum Pump Oil Only
- Energy Efficient
- Voltage: Standard, 220v, 50-60Hz
- Intake Port: KF25
- Dimensions: 23.9" x 7.5" x 17.8"
- Weight: 67 lbs

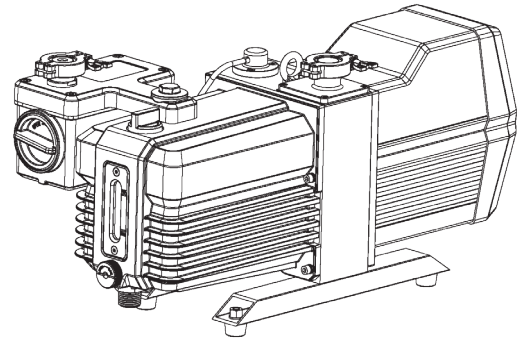

DIMENSIONS 23.9" X 7.5" X 17.8"

FEATURES

DIMENSIONS 33.5" W X 37.25" D X 70" H

