

GLASS DOOR MERCHANDISER FREEZERS

 MODEL: MXM2-48FHC MXM2-48FBHC

MXM2-48FHC



MXM2-48FBHC

Maxx Cold Glass Door Merchandisers are designed for durability and visual appeal to display your product. The glass door merchandisers are energy efficient and effective at displaying product at the right temperature to preserve freshness and prolong shelf life. Simple-to-use, programmable solid-state digital controls deliver accurate temperature regulation.

FEATURES AND CONSTRUCTION

- Constructed of a powder coated steel exterior and powder coated aluminum interior
- Triple pane, heated, insulated self-closing glass doors
- Interior LED lighting
- Bottom mounted compressor
- Eight (8) adjustable heavy-duty PE-coated wire shelves
- Four (4) rollers (2 with leveling feet)
- Digital controls with LED temperature display
- Automatic defrost system
- Provided with lock and key set for security
- Illuminated top panel for advertising/promoting products
- Equipped with integrated condensate evaporator therefore no drain line connection is needed

ELECTRIC

230V / 60Hz / 1Ph
6' (2m) NEMA L14-20 cord set included



NEMA L14-20

NOMINAL STORAGE CAPACITY

MXM2-48FHC/48FBHC..... 48 Cu Ft (1359 L)

TEMPERATURE

Holding temperature 0°F to 10°F (-18°C to -12°C)

- Oversized refrigeration system delivers optimum storage temperature and rapid temperature recovery

3RD PARTY APPROVALS



Intertek

Certified to ANSI NSF 7



Intertek

Certified to ANSI UL 471



Zero Ozone Depletion Potential

MAXX COLD WARRANTY (USA / CANADA)

Contact Maxx Cold for warranty statement at
TechnicalServices@TheLegacyCompanies.com or 877.368.2797

MXM2-48FHC / MXM2-48FBHC

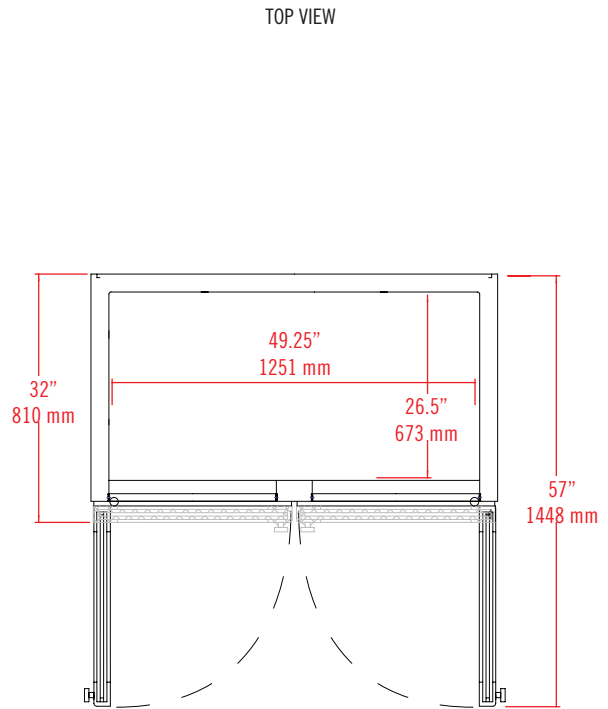
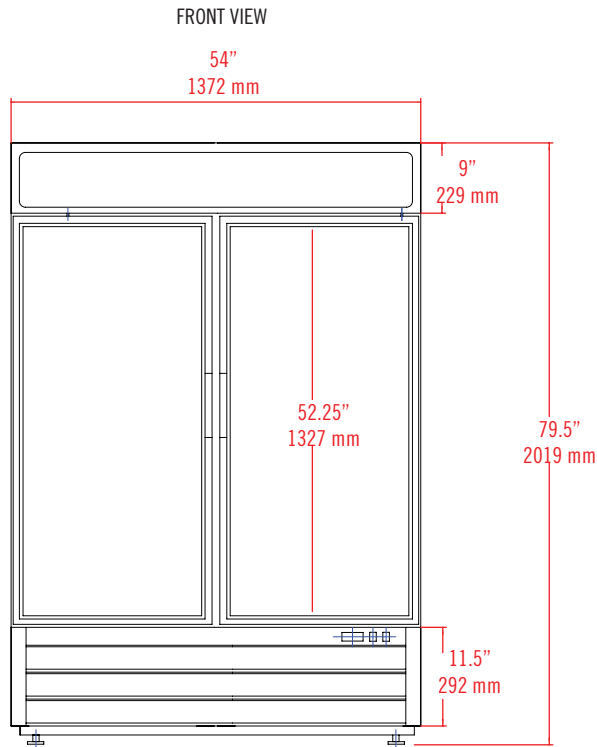

BACKLIT DISPLAY PANEL

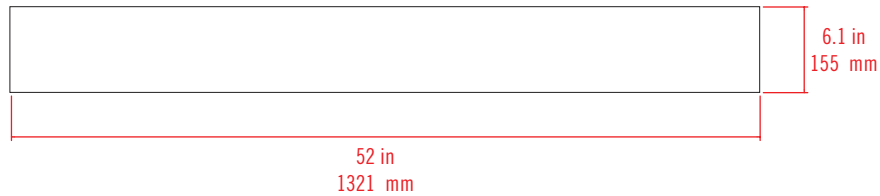

| MODEL | EXTERNAL DIMENSIONS | INTERNAL DIMENSIONS | NOMINAL CAPACITY | HOLDING TEMPERATURE RANGE | AMP DRAW | SHIPPING WEIGHT | REFRIGERANT AND CHARGE SIZE | DOORS / SHELVES | ELECTRICAL |
|-------------|---|---|----------------------|---------------------------------|----------|---------------------|-----------------------------|-----------------|-------------------|
| MXM2-48FHC | 54" x 32" x 79.5" (1372 x 810 x 2019 mm) | 49.25" x 26.5" x 52.25" (1251 x 673 x 1327 mm) | 48 Cu Ft (1359 L) | 0°F to 10°F (-18°C to -12°C) | 6.5A | 490 lbs (223 kg) | R-290A 5.29 oz (167 g) | 2 / 8 | 115V / 60Hz / 1Ph |
| MXM2-48FBHC | 54" x 32" x 79.5" (1372 x 810 x 2019 mm) | 49.25" x 26.5" x 52.25" (1251 x 673 x 1327 mm) | 48 Cu Ft (1359 L) | 0°F to 10°F (-18°C to -12°C) | 6.5A | 490 lbs (223 kg) | R-290A 5.29 oz (167 g) | 2 / 8 | 115V / 60Hz / 1Ph |

INSTALLATION

- Units are equipped with roller wheels and leveling feet. Swivel caster wheels are an available option for increased mobility.